

(No Model.)

C. H. KELLEY.
TOOL HOLDER FOR LATHES.

No. 332,806.

Patented Dec. 22, 1885.

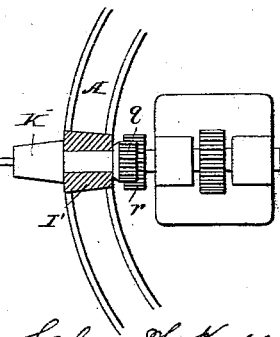
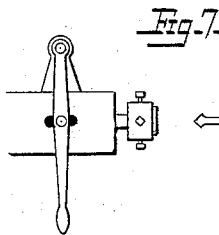
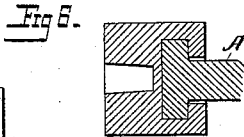
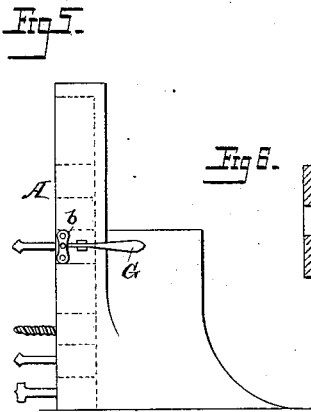
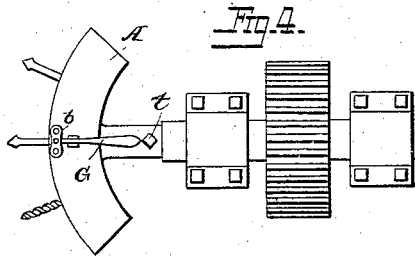
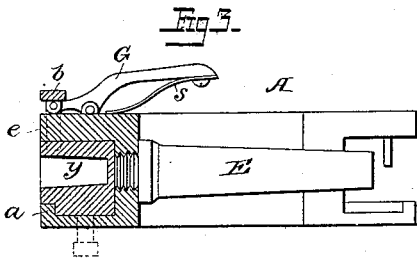
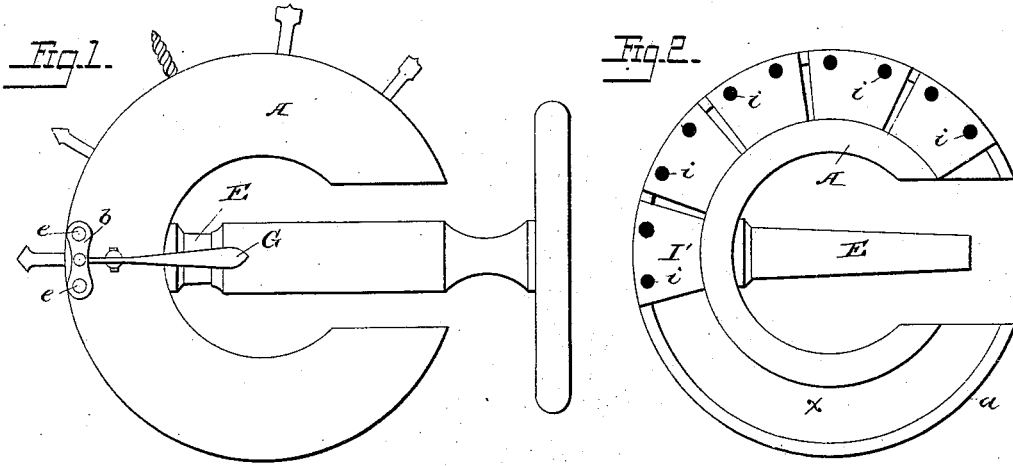

Attests:
John G. Hinkel Sr.
A. C. S. Farnsworth.

Chas. H. Kelley,
Inventor:
By J. W. Foster & Freeman
Attys.

UNITED STATES PATENT OFFICE.

CHARLES H. KELLEY, OF REVERE, ASSIGNOR OF ONE-HALF TO FRANCIS C. PERKINS, OF SOMERVILLE, MASSACHUSETTS.

TOOL-HOLDER FOR LATHES.

SPECIFICATION forming part of Letters Patent No. 332,806, dated December 22, 1885.

Application filed October 19, 1885. Serial No. 180,323. (No model.)

To all whom it may concern:

Be it known that I, CHARLES H. KELLEY, a citizen of the United States, and a resident of Revere, in the county of Suffolk and State of Massachusetts, have invented certain new and useful Improvements in Tool-Holders for Lathes, of which the following is a specification.

My invention is a tool-holder for lathes, &c.; and it consists, essentially, of a support or head adapted to be arranged in suitable position upon the lathe, and a series of tool-carriers movable upon the said head, and independently adjustable in the same path that each may be secured in operative position in respect to the spindle of the lathe.

My invention may be carried out in appliances constructed in different ways, some of which are illustrated in the accompanying drawings, in which—

Figure 1 is a plan view of my tool-holder, showing the same applied to the tail-stock of a lathe. Fig. 2 is a sectional plan of a holder. Fig. 3 is a central section of Fig. 1. Fig. 4 is a plan, and Fig. 5 is an elevation, and Fig. 7 is a sectional plan, illustrating different forms of holders embodying my invention. Fig. 6 is a section showing a modified form of connection between the head and tool-carrier.

The holder consists, essentially, of a series of tool supports or carriers and a head adapted to receive and guide the said supports and to hold them in available position, so that any one may be brought in line with the lathe-spindle and there secured. The head may be of any shape adapted to guide and hold the supports, and I have shown different-shaped heads as illustrations of some of the different forms in which my invention may be embodied, and the said head may be provided with a shank adapted to the socket of the dead-spindle of the tail-stock of the lathe, or it may be secured in any suitable manner upon the bed of the lathe, but in such position that any one of the tool-carriers may be guided into line with the lathe-spindle.

In the construction shown in Figs. 1, 2, and 3, the head A consists of a curved block with a peripheral groove, *x*, adapted to receive a series of sector-like carriers, which are confined

in the groove by a flange, *a*, so that they can only be withdrawn from the ends of the groove, and so that they can slide freely therein to bring any one of them to the position shown by the carrier I', Figs. 2 and 3, in which case the tool supported by the carrier will be axially in line with the spindle of the lathe, and the head is provided with a suitable locking device, whereby the carrier may be secured in position after adjustment.

Such a locking device may be a set-screw. (Shown in dotted lines, Fig. 3.) I prefer, however, an automatic spring-lock. For instance, a cross-bar, *b*, is connected to two locking-pins, *e e*, which pass through openings in the upper side of the head A, and when any one of the carriers is in position enter sockets *i* in the upper face of the latter, the cross-bar being connected to a lever, G, pivoted to studs at the top of the head and acted upon by a spring, *s*, so as to throw down the locking-pins as soon as the openings *i* coincide with the ends thereof. By pressing on the end of the lever G the pins may be raised and the carrier released.

The tools may be secured to the carriers in any suitable manner—for instance, each carrier may be provided with a socket, *y*, adapted to receive the butt-ends of the tools.

By the use of a head carrying a series of tool supports or carriers confined thereto, but sliding readily thereon, and each capable of being locked in line with the lathe-spindle, I am enabled to readily bring any tool into operative position with the work without the use of the usual expensive turrets; and it will be seen that the number of tools for any particular series of operations may be readily increased by simply increasing the number of carriers.

In the construction of head shown in Figs. 1, 2, and 3, the head is provided with a central shank, E, which is tapering to fit the socket of the dead-spindle in the tail-stock; but this mode of attachment, while convenient, is not essential, nor is it necessary to support the head by means of the tail-stock. For instance, the head may be a straight grooved bar supported in a vertical position on the bed of the lathe, as shown in Fig. 5, the carriers sliding vertically.

In Fig. 4 the head is shown as curved in

form, but to a less degree than the head illustrated in Figs. 1, 2, and 3; but, instead of being connected to the dead-spindle, it is shown as secured to the revolving spindle of the lathe

5 by a set-screw, *t*, so as to revolve with the said spindle, in which case, of course, the work will be brought toward each tool as it is brought centrally to position by the adjustment of the carrier, as before described.

10 In some instances the tool-carriers may be provided with revolving socketed spindles *K*, as shown in Fig. 7, each spindle having a pinion, *g*, which is revolved by a toothed wheel, *n*, on the spindle of the lathe as it is brought

15 above and into gear therewith, the carriers sliding adjustably in the head *A*, as before described, so that only the socketed spindle that is in line with the work-holder is revolved. In such case the work is supported by a suitable

20 chuck capable of adjustment to and from the tool. The head is not necessarily grooved to support the carriers, as each of the latter may have a T-groove adapted to a T-head, as shown in Fig. 6.

25 Without limiting myself to the precise construction and arrangement of parts shown, I claim—

1. The combination, in a tool-holder for lathes, of a head and a series of sliding tool-

carriers supported by the head and independently adjustable in the same path, to bring each in axial line with the work, substantially as set forth.

2. A head adapted for attachment to a lathe, in combination with a series of sliding tool-carriers independently movable in the same path in and supported by the head, an a locking device, whereby each carrier may be locked in position in line with the lathe-spindle, substantially as set forth.

3. An attachment for lathes, consisting of a head supporting a series of sliding tool-carriers, said head being provided with a shank adapted to be connected to and supported by the tail-stock of the lathe, substantially as described.

4. A tool-holder for lathes, consisting of a curved head supporting a series of tool-carriers sliding independently in the same path, and provided with a locking device and with a projecting shank, substantially as set forth.

In testimony whereof I have signed my name to this specification in the presence of two subscribing witnesses.

CHARLES H. KELLEY.

Witnesses:

ORA C. MAGOON,
S. H. HILL.